

## Operating Instructions

V-VCS 200 | 300 and V-VCX 200 | 300

Vacuum pump



V Serie  
V Series  
Drehschieber  
Rotary Vane



**Table of contents**

<b>1</b>	<b>Foreword</b> .....	<b>4</b>
1.1	Principles .....	4
1.2	Target group .....	4
1.3	Supplier documentation and accompanying documents .....	4
1.4	Directives, standards, laws .....	4
1.5	Copyright .....	4
1.6	Disclaimer .....	5
1.7	Technical terms and abbreviations .....	5
<b>2</b>	<b>Safety</b> .....	<b>6</b>
2.1	General .....	6
2.2	Labelling of warnings .....	6
2.3	Symbols and meaning .....	6
2.4	Intended use .....	8
2.5	Inadmissible operating modes .....	8
2.6	Personnel qualification and training .....	8
2.7	Personal protective equipment .....	9
2.8	Safety-conscious working .....	9
2.9	Responsibilities of the user .....	10
2.10	Hazardous substances .....	10
	2.10.1 Conveying media .....	10
	2.10.2 Auxiliary materials and lubricant .....	10
2.11	Safety equipment, monitored functions .....	11
2.12	Emergency Stop / Emergency Off .....	11
2.13	Protection of environment .....	11
<b>3</b>	<b>Transport and storage</b> .....	<b>12</b>
3.1	Transport .....	12
	3.1.1 Unpack and check the as-delivered condition .....	12
	3.1.2 Lifting and transporting .....	12
3.2	Storage .....	13
	3.2.1 Ambient conditions during storage .....	13
<b>4</b>	<b>Product overview and functioning</b> .....	<b>14</b>
4.1	Product Overview .....	14
4.2	Data plate .....	15
4.3	Description .....	15
4.4	Fields of application .....	16
4.5	Adjustable gas ballast valve .....	16
<b>5</b>	<b>Installation</b> .....	<b>17</b>
5.1	Preparation of installation .....	17
5.2	Installation .....	17
5.3	Connection of pipes .....	18
5.4	Check lubricating oil .....	19
5.5	Connection of motor .....	19

<b>6</b>	<b>Commissioning and decommissioning</b>	<b>20</b>
6.1	Start-up	21
6.1.1	Installation check	21
6.1.2	Check the rotation direction	21
6.2	Operation	21
6.2.1	Check the oil level	21
6.2.2	Standstill of the machine	22
6.3	Decommissioning	22
6.3.1	Decommissioning of the machine	22
6.3.2	Storing the machine	22
6.4	Recommissioning	22
<b>7</b>	<b>Maintenance and repair</b>	<b>23</b>
7.1	Ensure operational safety	23
7.2	Maintenance table	24
7.3	Preparing maintenance works	25
7.4	Clean vacuum pump	25
7.5	Cleaning of filter	25
7.5.1	Clean the mesh filter in the suction flange	25
7.5.2	Clean the filter cartridge of the gas ballast valve	26
7.6	Lubricating Oil	26
7.6.1	Refilling of oil	27
7.6.2	Oil change	27
7.7	De-oiling elements	28
7.8	Oil cooler and fan	29
7.9	Motor and coupling	30
7.9.1	Motor	30
7.9.2	Coupling	30
7.10	Repair / service	31
7.11	Spare parts	31
<b>8</b>	<b>Errors</b>	<b>33</b>
8.1	Table of malfunctions	33
<b>9</b>	<b>Disassembly and disposal</b>	<b>36</b>
9.1	Disassembly	36
9.2	Disposal	36
<b>10</b>	<b>Technical Data</b>	<b>37</b>

## Foreword

# 1 Foreword

## 1.1 Principles

These Operating Instructions:

- are a part of the following oil-flooded rotary vane vacuum pumps models V-VCS200 | 300 and V-VCX200 | 300.
- Describe how to use these pumps safely and properly in all life phases and they apply to all responsible persons
- Include general information on installation, commissioning, maintenance and inspection
- Must be available at the place of application

Figures presented in these Operating Instructions serve for better understanding and can deviate from the components installed. This does not influence the validity of the details set out in the instructions.

## 1.2 Target group

Target group for these Operating Instructions are the technically trained specialist personnel which have been qualified by appropriate training and instruction.

## 1.3 Supplier documentation and accompanying documents

Document	Contents	No.
Supplier documentation	Operating Instructions	BA 236
	Declaration of Conformity	C 0086
	Declaration of no-objection	7.7025.003.17
Spare parts list	Spare parts documents	E 236
Data sheet	Technical data and characteristic curves	D 236
Info sheet	Water vapour compatibility for oil-flooded vacuum pumps	I 200
Info sheet	Storage guideline for machines	I 150
Info sheet	Storage guideline for lubricants	I 100

## 1.4 Directives, standards, laws

See Declaration of Conformity.

## 1.5 Copyright

These Operating Instructions are intended for the customer's internal purposes.

Unless expressly permitted, passing on to third parties, copying of these documents, except for internal purposes, as well as using and providing their contents to third parties, even in excerpts, is prohibited.

Contraventions will lead to claims for damages.

## 1.6 Disclaimer

Please note that we cannot accept any liability for damages arising from failure to observe the instructions. Gardner Denver Schopfheim GmbH does not assume liability for the following cases:

- Not intended use
- Not complying with these instructions
- Nonobservance of all documents and specifications belonging to the overall documentation
- Erection, operation, maintenance and repair by insufficiently qualified staff
- Modification or removing of the part or serial number
- Using spare parts that have not been approved by **Gardner Denver Schopfheim GmbH**
- Unauthorised modifications to the machine or the accessories supplied by **Gardner Denver Schopfheim GmbH**

Please, also consider that repairs are only allowed to be done by authorised workshops using original spare parts; otherwise our guarantee will expire.

## 1.7 Technical terms and abbreviations

Term	Explanation
Machine	Pump and motor combination ready for connection
Motor	Pump drive motor
Vacuum pump	Machine for creating underpressure (vacuum)
Rotary vane	Design or operating principle of the machine
Suction capacity	Flow rate of a vacuum pump referred to the condition in the inlet connection, specified in m <sup>3</sup> /h
Final pressure (abs.)	The maximum vacuum that a pump reaches while the inlet opening is closed, displayed as absolute pressure in mbar (abs.)
Permanent vacuum	Vacuum or the inlet pressure range, at which the pump operates in continuous operation. The permanent vacuum or inlet pressure is $\geq$ than the final vacuum and $<$ than the atmospheric pressure.
Noise emission	Noise emitted at a specific loading state indicated as a numeric value, sound pressure level dB(A) as per EN ISO 3744.

Abbreviation	Meaning
Fig.	Figure
Tab.	Table
V-VCS	Vacuum pump, standard design
V-VCX	Vacuum pump with increased water vapour compatibility

## 2 Safety

The manufacturer is not responsible for damage due to non-observance of the whole documentation.

### 2.1 General

These operating instructions contain basic instructions for installation, commissioning, maintenance and inspection work which must be obeyed to ensure the safe operation of the machine and prevent physical and material damage.

Observe the safety instructions in all chapters.



The operating instructions must be read by the responsible technical personnel / user before installing and commissioning and must be fully understood. The contents of the operating instructions must always be available on site for the technical personnel/user. Instructions attached directly to the machine must be obeyed and must always remain legible. For example, this applies:

- Symbols for connections
- Data plate and motor data plate
- Information signs and warning plates



The data plates on the vacuum pump may not be removed, even if the machine is resold. For all queries about the product, please always quote the serial number.





The operating company is responsible for observing local regulations.

### 2.2 Labelling of warnings

Warning	Danger level
 <b>DANGER</b>	...warns of a hazardous situation, which will lead to death or life-threatening injuries if not avoided.
 <b>WARNING</b>	...warns of a potentially dangerous situation, which can lead to death or serious injuries if not avoided.
 <b>CAUTION</b>	...warns of a hazardous situation, which can cause slight or medium personal injuries if not avoided.
<b>NOTICE</b>	...warns of a situation that can cause damages to or destruction of material assets if not avoided.

### 2.3 Symbols and meaning

Symbol	Explanation
	Instructions, action
a), b),...	Instructions in several steps
	Results
	Reference

Symbol	Explanation
<p>Warning signs</p> 	<p>Obey all safety instructions with this symbol in order to avoid injury or death.</p> <p>Warns of potential risk of injury</p> <p>Warns of electrical voltage</p> <p>Warns of suspended loads</p> <p>Warns of hot surface</p>
<p>Mandatory signs</p> 	<p>Obey all instructions with this symbol in order to avoid injury or death.</p> <p>Observe the Operating Instructions</p> <p>Wear eye protection</p> <p>Wear protective gloves</p> <p>Wear safety shoes</p> <p>Wear ear protection</p> <p>Disconnect the plant and secure it against unexpected restart</p>
	<p>Information, note</p>
	<p>Protection of environment</p>

### 2.4 Intended use

The machine is suitable for conveying the following media:

- in the VCS version (CD):  
all non-explosive, non-combustible, non-aggressive and non-poisonous dry gases and gas-air mixtures
- in the VCX version (XD):  
all non-explosive, non-combustible, non-aggressive and non-poisonous damp gases and gas-air mixtures

The machine must only be operated in such areas as are described in the operating instructions:

- Only operate the machine in technically perfect condition
- The machine must only be operated at an ambient temperature and inlet temperature of between 12 and 40 °C  
Please contact us for temperatures outside this range.
- The permissible back pressure may not be exceeded (see chapter 5.3)

Any use extending beyond this use is seen as not in accordance with the intended use.

The intended use also includes the compliance with the operating data and operating agents specified in the operating instructions, the listed maintenance works, as well as the details in the documentation issued by the manufacturers of components and attachments.

If used under critical conditions and/or in case of any doubts, please contact the manufacturer. Non-observance can cause machine failures.

### 2.5 Inadmissible operating modes

- Extracting, conveying and compressing explosive, inflammable, aggressive or poisonous media, e.g. dust as per ATEX zone 20-22, solvents as well as gaseous oxygen and other oxidising agents
- Erection and operation in potentially explosive environment (explosive gas/vapour/mist-air mixtures or dust-air mixtures or hybrid mixtures of air and flammable substances)
- Using the machine in non-commercial plants unless the necessary precautions and protective measures are taken in the plant
- Continuous operation outside the intake pressure ranges (see also chapter 4.4):  
V-VCS: 0,5 - 500 mbar (abs.)  
V-VCX: 3,0 - 500 mbar (abs.)
- Operation of the machine when it is only partially assembled
- Using the machine in areas with ionising radiation
- back pressures on the outlet side of more than +100 mbar
- Modifications to machine and accessories
- Operation by not or not sufficiently qualified personnel

### 2.6 Personnel qualification and training

All works are only allowed to be done by qualified and trained specialist personnel of legal age. Unauthorised persons are not allowed to stay within the area of the vacuum pump and must be kept away from the danger zone by suitable measures.

- Ensure that people entrusted with working on the machine have read and understood these operating instructions before starting work, particularly the safety instructions for installation, commissioning, maintenance and inspection work
- Responsibilities, competences and monitoring of personnel must be regulated by the operating company.



- The following works are only allowed to be done by technical specialist personnel, who have been trained and instructed for the works assigned:
  - Transport only by forwarding agents
  - Erection, commissioning, maintenance and inspection works, as well as troubleshooting by specialist personnel (e.g. locksmith, mechanics)
  - Works on the electrical system are only allowed to be done by electricians
- Personnel to be trained and laypersons may only carry out work on the machine when under the supervision of authorised specialist personnel and must be instructed about possible hazards in a safety instruction.

**Specialist personnel:**

Persons that can evaluate work assigned to them and evaluate possible risks as a result of their training, knowledge and experience as well as the applicable regulations.

**Qualified electrician:**

Specialist personnel that has obtained an electrotechnical specialist education and is familiar with work for setting up, operation and maintenance of electrical systems and operating material.

**Unauthorised persons:**

Unauthorised persons are persons who cannot appropriately prove that they are qualified, trained, or instructed for the works on the vacuum pump. In addition, those persons shall be seen as unauthorised who, due to their physical, cognitive, and health abilities, are not able to recognise hazards caused by the vacuum pump.

**2.7 Personal protective equipment**

The user must make sure that the required protective clothing and protective equipment is available on the plant and used by the personnel. The national legal provisions and the national regulations for industrial safety must be observed.

Recommended protective equipment:



Wear eye protection



Wear protective gloves



Wear safety shoes



Wear ear protection

**2.8 Safety-conscious working**

The following safety regulations apply in addition to the safety instructions and intended use listed in these instructions:

- Accident prevention regulations, safety and operating regulations
- Standards and laws in force
- Hot parts of the machine must not be accessible during operation or must be fitted with a guard
- Risks arising from electrical energy must be eliminated
- The machine must not come into contact with flammable materials. Risk of fire due to hot surfaces, output of hot pumped media or cooling air

### 2.9 Responsibilities of the user

During the whole operating period of the machine, the operating company is obliged to prove that the limits have been met and the required maintenance and inspection works have been performed.

The user must ensure that:

- All works for installation, commissioning and maintenance are carried out by authorised and qualified specialist personnel, who gained enough information by an in-depth study of the operating instructions
- All works on electrical equipment are done by an electrician in compliance with the regulations for electrical installations
- The Operating Instructions are always available in the site of operation of the vacuum pump for the whole life phase
- All safety instructions and signs on the vacuum pump are always complete and legible
- The operating and maintenance personnel take note of all safety instructions - especially of information provided in these Operating Instructions - and observe them
- The personal protective equipment is available and is used by the personnel
- All safety-relevant regulations are met
- Unauthorised persons cannot enter the operating site
- Fire warning and firefighting possibilities have been installed and are active
- These Operating Instructions shall be amended by working instructions, as well as the duties to supervise and report. With this they shall consider the operational distinctions. Among others, it refers to instructions referring to:
  - Organization of work
  - Work procedures
  - Specialist personnel assigned

In the event of accidents caused by the vacuum pump notify the Gardner Denver Schopfheim GmbH. Please find contact data on the back page.

### 2.10 Hazardous substances

#### 2.10.1 Conveying media

Machinery that may have contact to hazardous substances can cause serious burns, cauterisation or poisoning during disassembly, maintenance and repair work.

- Before using our services each time, for occupational safety and environmental protection reasons, it is necessary to indicate and declare hazardous substances on or in the device.
- Send the declaration of clearance filled in and signed back to Gardner Denver.  
If no declaration takes place, we must assume that the device is free from such substances. In case of doubt, our service department reserves the right to reject the acceptance until the safety has been determined without doubt.

#### 2.10.2 Auxiliary materials and lubricant

Incorrect auxiliary materials and lubricants may decompose at high temperatures. The resulting vapours may be harmful to health and cause fires.

- Use exclusively the recommended auxiliary materials and lubricants
- Observe the oil recommendation sign on the pump
- Observe the safety data sheets of the substances used
- Ensure proper use
- Observe the maintenance intervals

### 2.11 Safety equipment, monitored functions

Missing or non-functional safety equipment may lead to dangerous operating states and thus result in life-threatening injuries.

- Do not modify or bypass safety equipment and safety functions
- Check the function at regular intervals

### 2.12 Emergency Stop / Emergency Off

Missing safety equipment may lead to hazardous operating states. This can result in severe to mortal injury.

- The vacuum pump does not have its own Emergency Stop or Emergency Off. This **must** be implemented by the user by, e.g. the integration of the pump in the user's safety plan.

### 2.13 Protection of environment

Environmental damage may be caused by the incorrect disposal of operating material and materials. For questions about environmental protection as well as national regulations, please consult your local disposal company.

- All operating materials as well as all gases, vapours or liquids, e.g. lubricating oil escaping during operation and maintenance must be collected and disposed of in an environmentally friendly manner.

### 3 Transport and storage

#### 3.1 Transport

**! WARNING**



**Death by falling down or tipping over of the transported goods!**

Falling or tipping over of transported goods can cause serious or fatal injuries. Limbs can be crushed.

- Select the lifting device according to the total weight to be transported.
- Secure the machine against tipping over and falling.
- Always attach the machine on all present load handling equipment. Attaching at only one point is forbidden.
- Do not stand underneath a suspended load.
- Put the goods to be conveyed on a horizontal base (max. inclination: 10° in all directions).

##### 3.1.1 Unpack and check the as-delivered condition

- a) Unpack the machine on receipt and check for transport damage.
- b) Immediately notify the manufacturer of transport damages.
- c) Check the scope of deliveries for completeness.
- d) Dispose of the packaging in accordance with the local regulations in force.

##### 3.1.2 Lifting and transporting

**! WARNING**



**Bodily injury resulting from improper operation!**

Improper operation of the lifting gear and the transported goods can cause serious or fatal injuries.

- Lift and transport the machine only on the permissible load handling equipment.
- Loads crosswise to the load handling equipment are not permitted.
- Avoid impact stress.
- Wear your personal protective equipment.

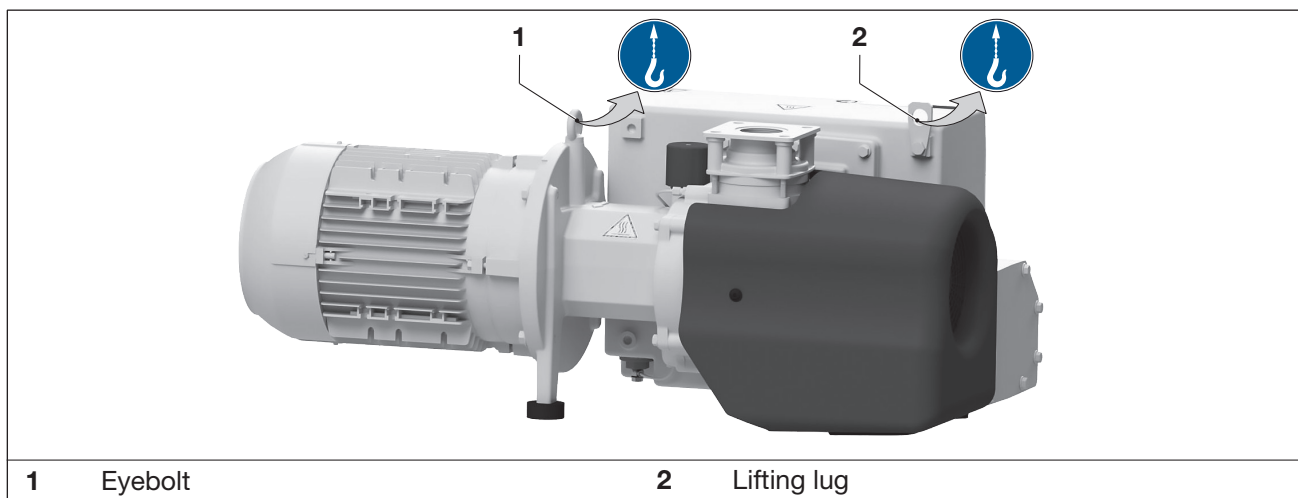

Fig. 1 Load handling equipment for lifting and transporting

The pump is supplied on a pallet.

- a) Unload the pump using a forklift or pallet truck and transport to the installation location.
- b) Tighten the eyebolt (Fig. 1/1) firmly.
- c) For lifting the machine, it must be suspended on the eyebolt and the lifting lug (Fig. 1/2) using the lifting device.
- d) Lift the pump from the pallet and align.

### 3.2 Storage

#### NOTICE

#### Material damage caused by improper storage!

Improper storage can damage the machine.

- Observe the storage conditions described below.

#### 3.2.1 Ambient conditions during storage

- Dust-free
- In a dry place
- Vibration free
- Protected against sun radiation
- Storage temperature: -10°C to +60 °C
- Rel. air humidity: max. 80 %
- Close the openings air-tight



The machine must be stored in a dry environment with normal air humidity. It should not be stored for more than 6 months.

For long-term storage (more than 3 months), it is useful to use a preservation oil rather than operating oil.

📄 See Info "Storage instructions", page 4.

## 4 Product overview and functioning

### 4.1 Product Overview

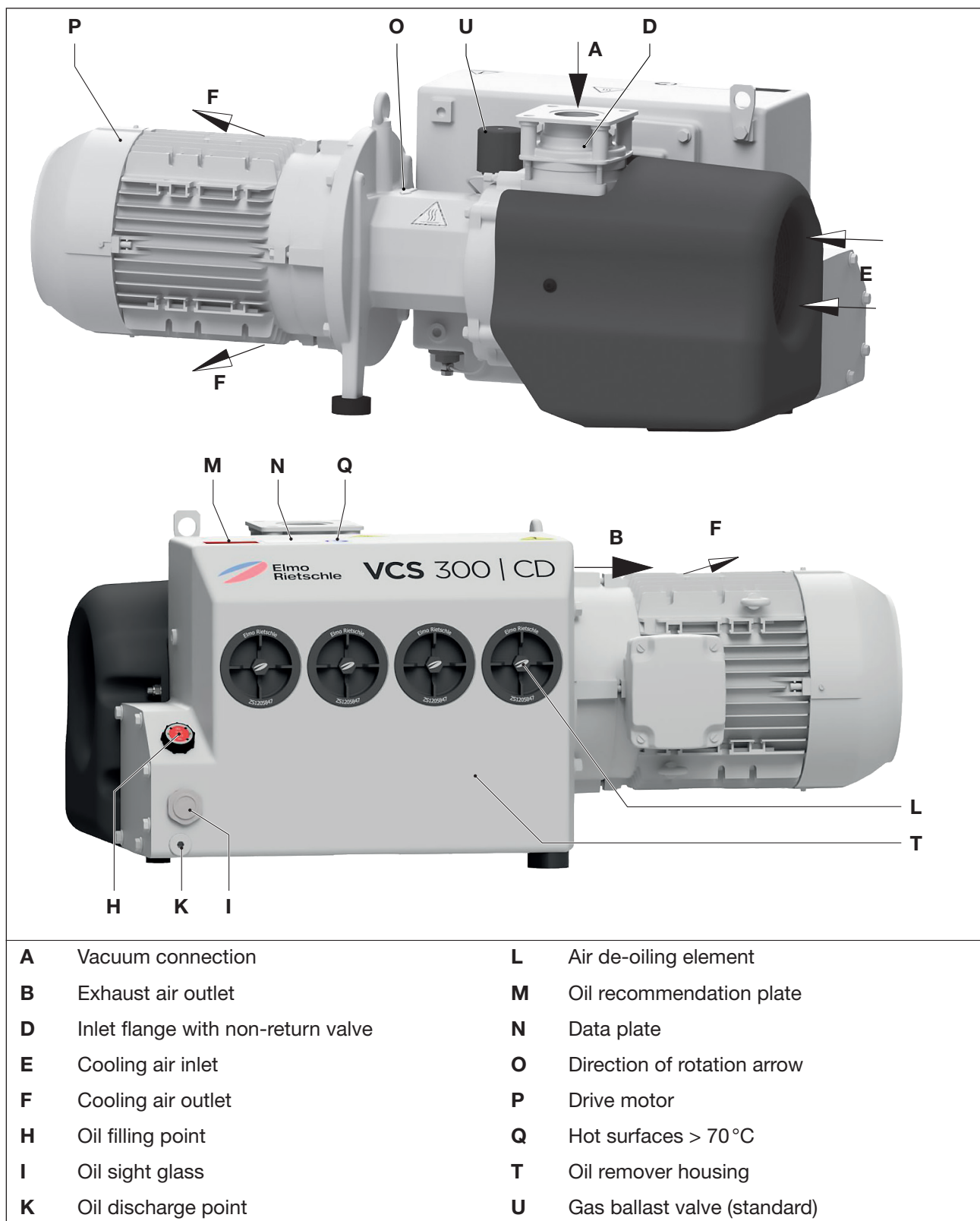

Fig. 2 Vacuum pump V-VCS 200 / 300

## 4.2 Data plate

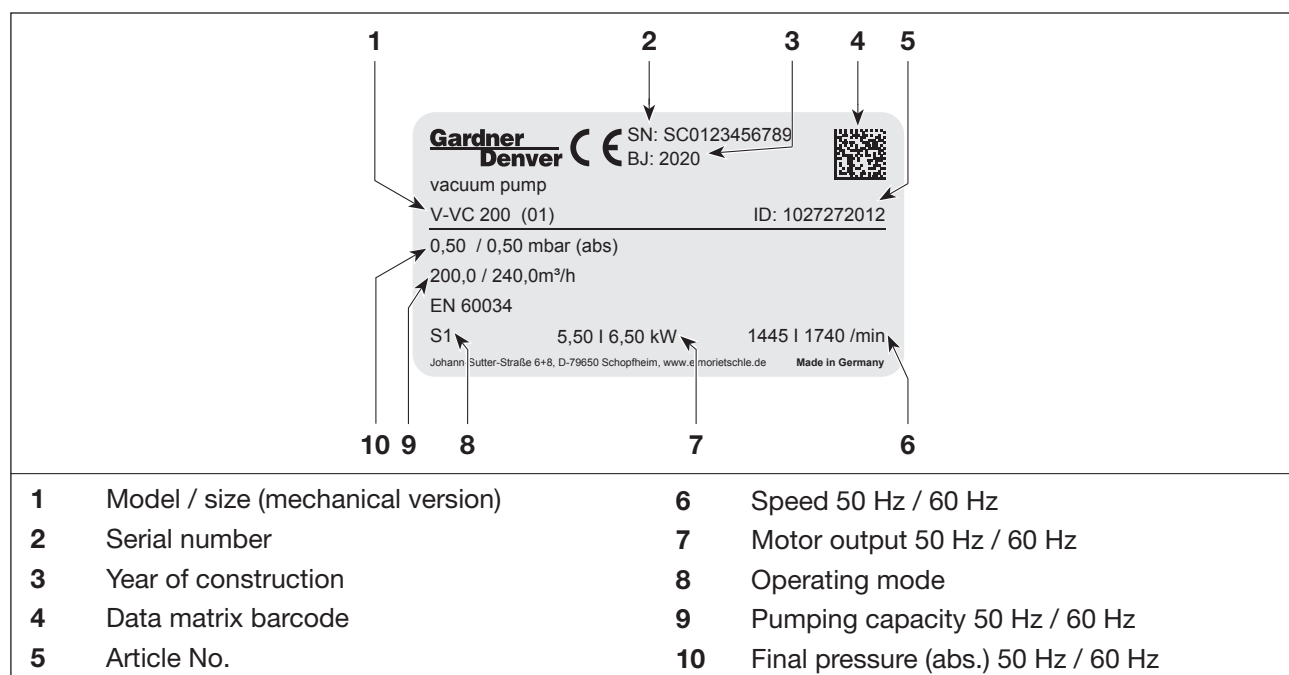

Fig. 3 Data plate

The following information is encoded as barcode:

- Material number (MA)
- Production order (PR)
- Serial Number (SC)

## 4.3 Description

The V-VCS/X 200|300 are single-stage oil flooded rotary vane vacuum pumps. The rotary vane divides the pump housing into several chambers whose volumes change periodically. The oil ensures for the sealing of the gap, an optimum lubrication and the dissipation of the compression heat.

The pumps have an integrated mesh filter on the suction side and on the outlet side an oil and oil mist separator to return the oil to the oil circulation system. With optimum air routing, a fan and an oil cooler ensure for the cooling of the oil and pump housing. An integrated non-return valve prevents the evacuated system from being ventilated after the pump has stopped for approx. 2 minutes.

When the pump is at operating temperature, a standard gas ballast valve (Fig. 2/U) prevents the condensation of low quantities of water vapour inside the pump. The water vapour compatibility may vary depending on the pump version (see Info I200).

It is driven via a coupling by a flanged, three-phase standard motor.

### Variant V-VCX

The functional parts are more resistant to water steam and solvents. In addition, glass-fibre reinforced slide gates (GF) are used that are made of epoxy resin. The gas ballast quantity was increased. Generally, the oil sump temperature was clearly increased compared with the standard design.

### 4.4 Fields of application

The oil-flooded rotary vane vacuum pumps V-VCS and V-VCX are suitable for creating vacuums. The nominal suction power with unrestricted suction is 200 and 300 m<sup>3</sup>/h at 50 Hz. Data sheet D 236 shows the dependency of the pumping capacity on the intake pressure.

These types are suitable for the evacuation of closed systems or for a continuous vacuum within the following intake pressure ranges:

- V-VCS: 0.5 to 500 mbar (abs.)
- V-VCX: 3.0 to 500 mbar (abs.).

If the machine is operated continuously outside these ranges there is the risk of oil leaking through the outlet opening. When evacuating closed systems the volume to be evacuated must be no more than 2% of the nominal pumping capacity of the vacuum pump.

**For continuous operation > 100 mbar (abs.), the next higher motor output should be used.**



If the unit is switched on more frequently (at regular intervals of approx. 10 times per hour) or at higher ambient temperatures and inlet temperatures, excess temperature limit of the motor winding and the bearings may be exceeded.

Contact the manufacturer regarding such operating conditions.

Observe the ambient and intake temperature (see chapter 2.4).

Observe the protection class of the motor (motor data sign).



If it is installed in the open air the unit must be protected from environmental influences, (e.g. by a protective roof).

### 4.5 Adjustable gas ballast valve

The pumps V-VCX include an additional gas ballast valve (Fig. 4/2) that can be variably adjusted via a ball valve (Fig. 4/3).

If humid gases or gas-air-mixtures are pumped, a ball valve can be opened, if necessary, to increase the gas ballast capacity. However, this reduces the maximum reachable end pressure (see chapter 4.4).

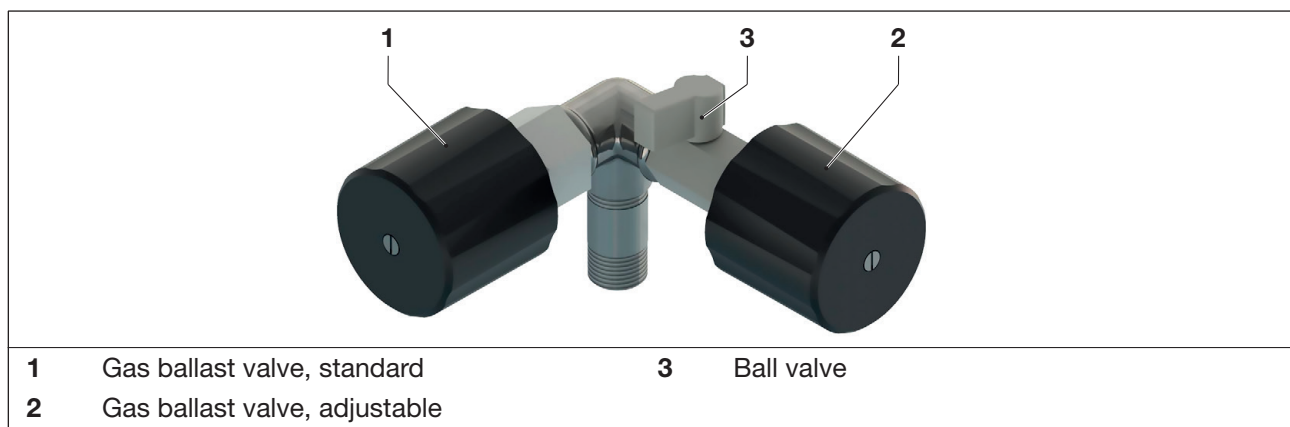

Fig. 4 Adjustable gas ballast valve



## 5 Installation

We urgently recommend having the installation carried out by qualified specialist personnel. Gardner Denver does not accept liability for damages caused by improper carrying out of installation.

### 5.1 Preparation of installation

Ensure the following conditions:

- Machine freely accessible from all sides
- Do not close ventilation grids and holes
- Sufficient space for installing and removing pipes and for maintenance work, particularly for the installation and deinstallation of the machine
- No influence by external vibrations
- Hot exhaust air from other machines may not be sucked in the cooling system
- Good ventilation in the installation room
- Suction flange (Fig. 2/D), Oil filling point (Fig. 2/H), Oil sight glass (Fig. 2/I), Oil drain (Fig. 2/K), Gas ballast (Fig. 2/U) and de-oiler housing (Fig. 2/T) must be easily accessible.
- For maintenance works, provide for a space of at least 50 cm around the machine.

### 5.2 Installation

#### CAUTION

#### Burns due to hot exhaust gases!

Place the freely blowing machine in a way that hazards due to hot exhaust gases are prevented.

#### NOTICE

#### Property damage caused by improper installation!

Improper erection and installation can damage the machine.

- The machine may only be operated when it is set up horizontally (Max. inclination: 1° in all directions).
- Secure the machine against tipping over and falling.
- The floor must be plane and even.
- The bearing surface must be designed to be able to carry the weight of the machine (see chapter 10 “Technical Data”).
- The bearing surface must be at least the same size as the machine.
- The non-return valve must not be removed.

#### NOTICE

#### Property damage from overheating!

Due to too low cooling capacity, the machine can overheat and can be damaged.

- Ensure for a good aeration and venting of the installation room. Observe the ambient temperature: min. +12 °C, max. +40 °C
- The cooling air inlets and the cooling air outlets must be at least 30 cm away from the adjacent walls. Cooling air coming out must not be sucked in again.

- Align the pump at the installation location and if necessary, bolt to the substrate.
- If available, check optional accessories for the correct mounting and correct electrical connection.



An output reduction is noticeable when installed at more than 1000m above sea level. In this case, please contact us.



It is possible to install the machine on a firm base without anchoring. When installing on a sub-structure we recommend fixing it with flexible buffers.

### 5.3 Connection of pipes



#### WARNING

#### Parts being ejected from over pressure!

Closing or narrowing of the exhaust air openings may lead to impermissible pressure in the machine. This could result in severe or mortal injury, components may be damaged.

- The exhaust air opening must not be closed or restricted.
- No filter may be installed on the exhaust air side.
- Counter pressures on the exhaust air side are only permissible up to + 100 mbar.
- Prevent liquids from accumulating in the exhaust line.
- Before connecting hose or pipelines, the blind plugs at the exhaust air outlet must be removed.
- Use only suitable pipelines.

#### NOTICE

#### Property damage due to high forces or torques!

If forces and torques during installation and operation are too high, the machine can be damaged.

- Only screw in pipes by hand.
- If necessary, use flexible connections.

#### NOTICE

#### Property damage due to missing ventilation!

For standstill times longer than two minutes, we recommend venting the connected suction line to atmospheric pressure in order to avoid possible damage to the machine.

- Provide for an air release position in the suction line, for instance a ball valve etc.

#### NOTICE

#### Property damage in case of parallel operation!

If parallel operation of multiple pumps is used, a switched off pump can be damaged due to the suction capacity of the operating pumps.

- For parallel operation, an external non-return valve must be installed in the suction line upstream of each pump.

The vacuum connection (Fig. 2/A) is located on the suction flange (Fig. 2/D).

- a) Remove the blind plugs on the suction connection (Fig. 2/A) and exhaust air outlet (Fig. 2/B).
- b) Connect the pipes with the vacuum connection (Fig. 2/A).
- c) The exhausted air can be blown out through the exhaust air outlet (Fig. 2/B) or conducted away using a hose or pipeline.
- d) Check that the maximum back pressure is not exceeded!



The suction capacity of the vacuum pump is reduced if the inlet pipe is too narrow and/or too long.

## 5.4 Check lubricating oil



The pumps are delivered with first oil filling. With this, it can happen that the oil has a dark colour due to graphite leaching. This does not have any influence on the performance of the pump.

- Check the lubricating oil level through the oil sight glass (Fig. 2/I) and top up, if necessary.
- Fill the lubricating oil (for suitable types see chapter 7.6 “Lubricating Oil”) via the oil filling point (Fig. 2/H) up to the upper edge of the sight glass (Fig. 2/I).
- Close the oil filling point.

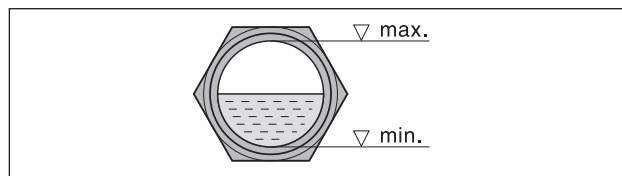

Fig. 5 Oil level

## 5.5 Connection of motor

**DANGER**



**Danger to life if the electrical installation has not been carried out professionally!**

Installation that has not been carried out professionally or properly can cause serious injuries or death. The whole electrical system can be destructed.

- The electrical installation must only be carried out by a qualified electrician observing EN 60204.
- The main switch must be installed by the operating company.
- The motor must be safeguarded via a motor protection switch. This must be installed by the operating company.

**NOTICE**

**Property damage due to wrong energy supply!**

Wrong operating voltages, frequencies or currents can cause loss of power or damages to the machine.

- The conditions at the installation location must comply with the details on the motor data plate.

Please find the electrical data of the motor on the data plate (Fig. 2/N) or the motor data plate. The motors comply with DIN EN 60034 and are designed in protection class IP 55 and insulation class F. The appropriate connection diagram is located in the terminal box of the motor (not existing for the version with plug connection).

Permissible tolerances:

- $\pm 5\%$  voltage deviation
- $\pm 2\%$  frequency deviation

- Compare the motor data with the data of the existing mains network (current type, voltage, network frequency, permitted current value).
- The direction of rotation of the motor must correspond with the direction of rotation arrow (Fig. 2/O) on the motor flange. Check the rotation direction!
- Connect the motor via the plug connection or directly on the terminal box.  
For securing, a motor protection switch and a strain relief provide for a screwed cable connection to connect of the connecting cable.



We recommend using motor protection circuit breakers with delayed switch off, depending on a possible excess current. Temporary excess current can occur when the machine is started under cold conditions.

## 6 Commissioning and decommissioning

 **WARNING**

### **Risk of injury due to improper operation!**

Improper operation of the machine can cause serious or fatal injuries.

- Only use the machine in accordance with the intended use. See chapter 2.4.

 **WARNING**

### **Risk of injury due to drawing in and trapping!**

Due to the high suction capacity it is possible that fingers are drawn in the inlet connection and injured.

- Do not put your hands onto the inlet connection to check the suction.
- By barriers or keeping sufficient distance make sure that parts of the body can be drawn into the inlet connection.

 **CAUTION**



### **Risk of injury due to hot surfaces!**

When the machine is at operating temperature the surface temperatures on the components may rise to above 70 °C. This can cause burns.

- Avoid touching the hot surfaces. They are marked by warning signs.
- Wear suitable protective gloves, if necessary.

 **CAUTION**



### **Risk of injury due to noise emission!**

High sound pressure level can permanently damage hearing.

- Observe measured sound pressure level, see chapter 10.
- When spending a long time in the vicinity of the running machine use ear protection to avoid permanent damage to hearing.

 **CAUTION**

### **Oil aerosols in the extracted air!**

In spite of the air oil removing system separating the oil mist to a large extent, the extracted air contains a small residue of oil aerosols. Breathing in these aerosols all the time could damage your health.

- The installation room must be well ventilated.

**NOTICE**

### **Property damage due to insufficient cooling!**

If the cooling air flow is reduced or interrupted, cooling of the machine cannot be ensured. This can cause reduced performance or blackout failure of the machine and damage the machine.

- Operation is only allowed with sufficient cooling air quantity.
- Make sure that the cooling air flow is not interrupted.

## 6.1 Start-up

### 6.1.1 Installation check



#### WARNING

#### Risk of injury!

A faulty installation as well as missing or non-functional safety equipment may lead to severe injury.

- Put the vacuum pump into operation only after it has been ensured that the installation is carried out flawless and the requirements for installation, assembly and electrical installation have been observed.

The following checks must be carried out:

- no transport or assembly damage of the vacuum pump and assembly steps attached
- the vacuum pump is standing safely on the substrate at a horizontal installation position
- Correct connection of the pipelines (inlet side, outlet side), check for leak tightness!
- Tight fit of the screw and flange connections
- Electrical installation complies with the specifications (connection diagram)
- The installation room is equipped with an adequate ventilation system
- Oil filled and oil level checked
- vacuum pump and pipelines cleaned
- check the function of optional accessories (if present)

### 6.1.2 Check the rotation direction



#### CAUTION

#### Risk of injury due to wrong direction of rotation!

Rotating backwards for a longer time can cause injuries due to drawing in and can damage the machine.

- Use a phase sequence indicator to check the direction of rotation (anti-clockwise).
- Keep a distance of 1 m to outlet and inlet connections.

The drive shaft direction of rotation is shown by the arrow for the direction of rotation (Fig. 2/O) on the motor flange.

- a) Start the motor briefly (max. two seconds) to check the direction of rotation. If looking at the motor fan, it must rotate clockwise.
- b) After correcting the direction of rotation if necessary, start the motor again and stop it again after 2 minutes in order to top missing oil up to the upper edge of the sight glass (Fig. 5/I). This topping up at the filling point (Fig. 2/H) must be repeated until all the oil pipes have been filled completely. The filling point must not be open when the pump is running.

## 6.2 Operation

### 6.2.1 Check the oil level

#### NOTICE

#### Property damage due to bad lubrication!

If the oil level is too low, this can cause damages to vacuum pump.

- Check oil level every day and, if necessary, refill oil.

- a) Check the oil level in the sight glass (Fig. 2/I) at least once daily.
- b) To refill the oil, switch off the machine and bleed to atmospheric pressure. See chapter 7.6.1 "Refilling of oil"

### 6.2.2 Standstill of the machine

For standstill times longer than two minutes, we recommend venting the connected suction line to atmospheric pressure in order to avoid possible damage to the machine.

## 6.3 Decommissioning

### 6.3.1 Decommissioning of the machine

#### **DANGER**



#### **Danger of death from touching live parts!**

Touching of live parts cause serious injuries or death.

- Disconnect the machine from the power supply by actuation of the main switch or disconnection of the plug and secure it against unexpected restart.
- Works on the electrical installation or electrical components must be carried out by an electrician only.

#### **CAUTION**



#### **Risk of injury due to hot surfaces!**

When the machine is at operating temperature the surface temperatures on the components may rise to above 70 °C. This can cause burns.

- Avoid touching the hot surfaces. They are marked by warning signs.
- Wear suitable protective gloves, if necessary.

- a) Switch the machine off.
- b) If available, close the cut-off device in the suction and pressure line.
- c) Disconnect the machine and all electrical components from the power supply.
- d) Depressurise the machine:  
slowly open the pipelines on the suction and pressure sides.  
⇒ The pressure reduces slowly.
- e) Remove the pipes and hoses.
- f) Seal the connections for inlet and outlet stubs using blind plugs or adhesive foil.
- g) If necessary, preserve and store the machine.

### 6.3.2 Storing the machine

📖 see also Section 3.2.1, Page 13

## 6.4 Recommissioning

- a) Check the condition of the machine (cleanliness, cabling etc.).
- b) Drain the preserving agents.

📖 For installation see Section 5 Page 17

📖 For commissioning see Section 6.1 Page 21

## 7 Maintenance and repair

### DANGER



#### Danger of death from touching live parts!

Touching of live parts cause serious injuries or death.

- Before starting any maintenance and repair works disconnect the machine by actuation of the main switch or disconnection of the plug and secure it against unexpected restart.
- Works on the electrical installation or electrical components must be carried out by an electrician only.
- Repair works are only allowed to be done by authorised specialists.

### CAUTION



#### Risk of injury due to hot surfaces!

When the machine is at operating temperature the surface temperatures on the components may rise to above 70 °C. This can cause burns.

- Before maintenance and repair works allow the machine to cool down.  
Exception: Oil change, here the machine shall be still warm, because then oil can flow off better.
- Wear suitable protective gloves, if necessary.

### CAUTION

#### Risk of injury due to missing safety devices!

Missing safety devices can cause injuries.

- Safety devices as well as safety guards on motor fans and ventilators may not be removed.

### 7.1 Ensure operational safety

Regular maintenance work must be carried out in order to ensure operational safety.

For some maintenance intervals we are offering service kits that include the necessary spare parts. Please find an overview in Tab. 2 on page 31.

The cleaning and oil change intervals strongly depend on how the machine is loaded (operating time, operating conditions, etc.) and the type of oil used. Depending on the pollution of the sucked in medium and the environmental conditions, the cleaning intervals of the inlet filters and the air de-oiling elements will be shorter. Extreme temperatures or pollutions can reduce the lifetime of the oil to 500 operating hours. The specified interval of up to 2,000 or 3,000 operating hours only applies to oil that has been delivered or is approved by Elmo Rietschle. Please find an overview in Tab. 3 on page 32.

For all works, observe the safety instructions described in chapter 2 “Safety”.

The whole plant should always be kept in a clean condition.

7.2 Maintenance table

Interval (Operating hours)	Maintenance activities	Chapter
daily	Check the oil level	6.2.1
Depending on the degree of pollution	Clean vacuum pump	7.4
At least 1 x per month	Check the pipes and screws for leaks and ensure their tight fit and if necessary re-seal or re-tighten.	—
	Check the terminal box and cable inlet holes for leaks and if necessary re-seal.	—
	Clean the ventilation slots on the machine and the motor cooling ribs.	—
	Cleaning the oil cooler	7.8
	Clean the fan and check it for material fatigue	7.8
Depending on how dirty the sucked in medium is or At least 1 x per month	Clean the mesh filter in the inlet connection	7.5.1
	Clean the filter cartridge in the gas ballast valve	7.5.2
500 h	First oil change	7.6.2
500 - 2000 h 500 - 3,000 h if Super-Lube is used or at least 1 x per year	Oil change	7.6.2
2000 h or Filter resistance of 700 mbar reached (accessories pressure monitoring system) or at least 1 x per year	Change the air de-oiling elements	7.7
at least 1 x per year	Check couplings for wear	7.9.2
As per manufacturer's instructions	Motor (maintenance, lubrication and cleaning)	7.9.1

Tab. 1 Maintenance table



### 7.3 Preparing maintenance works

- Switch the plant off electrically and secure it against unexpected restart.
- Vent the vacuum pump with atmospheric air; for this purpose open the shut-off valve on the inlet side.  
Exception: Clean the outside of the vacuum pump
- Allow the vacuum pump to fully cool down.  
Exception: Oil change, here the pump shall be still warm, because oil can then flow off better.
- Post the warning sign "Caution, maintenance works!".

### 7.4 Clean vacuum pump

The vacuum pump must regularly be checked for dust deposits and cleaned, if necessary. The cleaning interval depends on the operational requirements.

- Clean the vacuum pump with a damp cloth or using a vacuum cleaner. Remove dust deposits:
  - Between the cooling ribs of the motor
  - On the hood
  - Oil remover housing

Cleaning can also take place in connection with the cleaning of the oil cooler. See chapter 7.8.

### 7.5 Cleaning of filter

#### CAUTION



#### Danger of injury when dealing with compressed air!

When the filter is blown off with compressed air, loose solid particles or powder dust swirling around may cause injury to the eyes. Inhaling can damage lungs.

- Wear protective glasses and dust mask when cleaning the filter with compressed air.

#### NOTICE

#### Property damage due to insufficient maintenance of the air filter!

Performance of the machine is reduced by a polluted air filter and insufficient maintenance. This can cause damage of the machine.

- Regularly clean the mesh filter.
- Replace highly polluted or damaged mesh filters.
- During disassembly/assembly of the inlet flange make sure that not parts fall into the inlet flange.

#### 7.5.1 Clean the mesh filter in the suction flange

Depending on the pollution of the inlet medium, the mesh filter (Fig. 6/f<sub>1</sub>) has to be cleaned more or less by washing or blowing off or it must be replaced.

- Depending on the installation type, disassemble the pipeline at the suction flange.
- Take off the suction flange (Fig. 6/D) after releasing the screws (Fig. 6/s<sub>1</sub>).
- Clean the mesh filter (Fig. 6/f<sub>1</sub>).
- Check the non-return valve for contamination.
- Put on the suction flange (Fig. 6/D) and secure it with the bolts (Fig. 6/s<sub>1</sub>). Tightening torque: 25 Nm
- Check the function of the non-return valve. For this purpose, fit a cut-off device to the suction side (enclosed volume of at least 1 litre) and briefly start the vacuum pump. The vacuum reached must then remain constant.

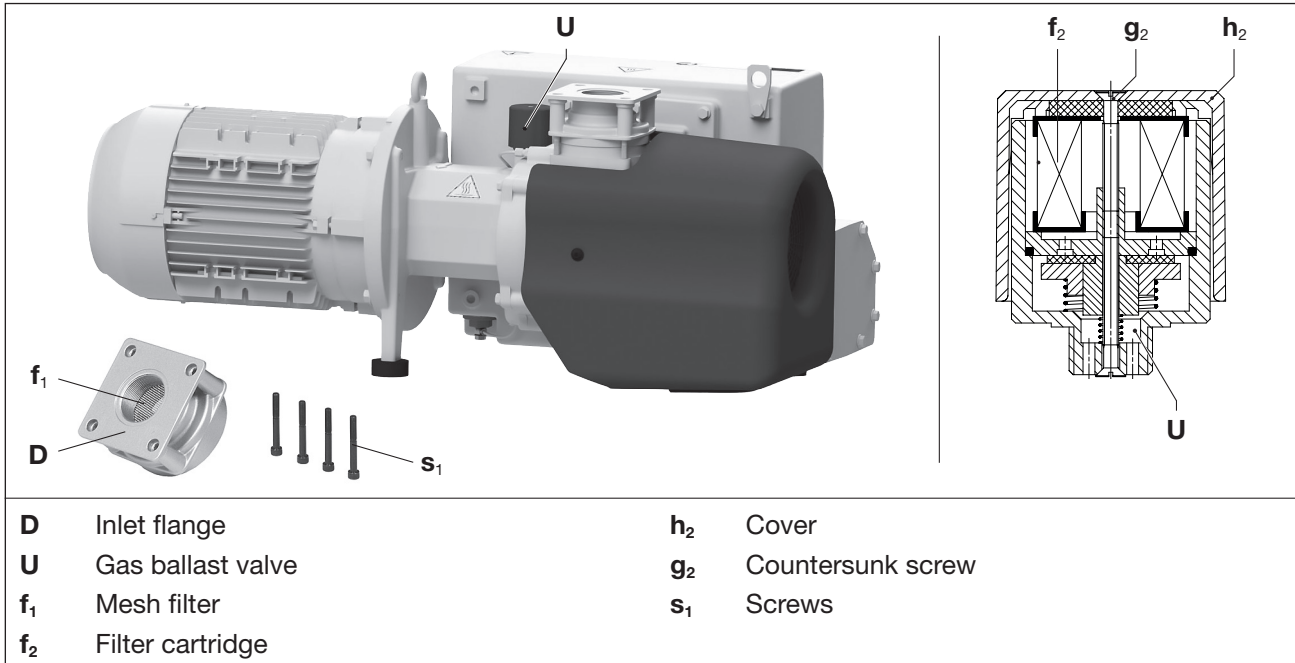

Fig. 6 Mesh filter and gas ballast valve

### 7.5.2 Clean the filter cartridge of the gas ballast valve

The pumps work with a gas ballast valve (Fig. 6/U). The inbuilt filter cartridge (Fig. 6/f<sub>2</sub>) must be cleaned more or less often depending on how dirty the medium flowing through is.

- By undoing the countersunk screw (Fig. 6/g<sub>2</sub>) and removing the plastic cover (Fig. 6/h<sub>2</sub>), the filter parts can be removed for cleaning.
- Clean the filter cartridge (Fig. 6/f<sub>2</sub>) by purging or replace it.
- Insert the filter cartridge (Fig. 6/f<sub>2</sub>) into the valve, put on the plastic hood (Fig. 6/h<sub>2</sub>) and secure with the countersink screws (Fig. 6/g<sub>2</sub>). Tighten the screw by hand.

## 7.6 Lubricating Oil

### ⚠ CAUTION



#### Risk of burns on hot equipment!

There is the risk of burning on hot equipment when changing oil.

- Allow the machine to cool down to approx. 40 °C (lukewarm).
- Avoid contact with the hot oil because the oil temperature can be higher than the ambient external temperature of machine.
- Wear suitable protective gloves, if necessary.

### ⚠ CAUTION



#### Risk of injury due to slipping and falling!

The floor can be slippery due to leaked oil and cause slipping, tripping or falling.

- For oil change wear non-slip shoes.
- Remove leaked oil immediately.



Always change the oil when the machine is at operating temperature and in an atmospherically ventilated area. If it is not completely emptied, the refilling quantity is reduced.

If you change the type of oil, empty the oil tank completely.



The waste oil must be disposed of in compliance with the local environmental protection regulations.

As operating agent, we recommend Elmo Rietschle oils, see oil recommendation plate (Fig. 7/M) as well as Tab. 3 on page 32:

- MULTI-LUBE 100
- SUPER-LUBE 100
- ECO-LUBE 100

The viscosity of the oil used must comply with ISO VG 100 as per DIN 3448. Also consider the safety data sheet of the oil type used.

If you want to change the oil type, please contact us.

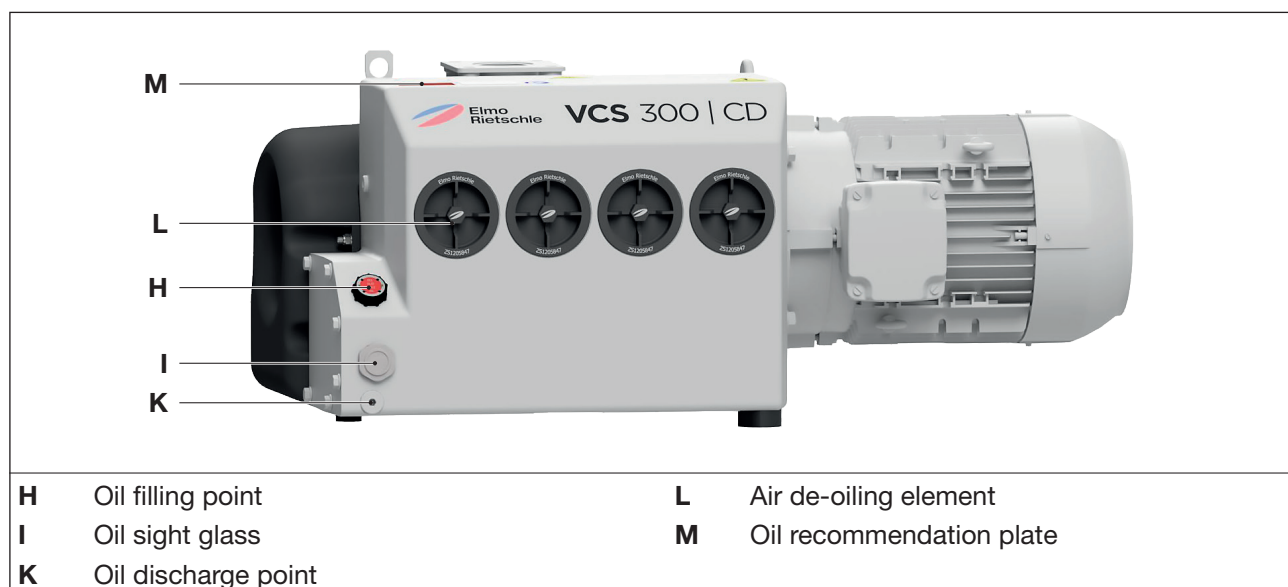

Fig. 7 Oil change and de-oiling

### 7.6.1 Refilling of oil

- Switch the machine off, secure it against accidental switching on and vent to atmospheric pressure.
- Open the cap of the oil filling point (Fig. 7/H) and refill oil until it reaches the upper edge of the sight glass (Fig. 7/I).
- Reclose the oil filling point.

### 7.6.2 Oil change

carry out the first oil change after 500 operating hours, further oil changes each after 500 to 2,000 operating hours. Reduce the change intervals accordingly depending on how contaminated the discharged medium is.

- Switch the machine off, secure it against accidental switching on and vent to atmospheric pressure. Let the pump cool down.
- Open the catch of the oil filling point (Fig. 7/H), open the oil discharge point (Fig. 7/K) and completely discharge the used oil.
- Close the oil discharge point (Fig. 7/K) and fill in new oil through the oil filling point (Fig. 7/H).
- Check the oil level in the sight glasses (Fig. 7/I).

### 7.7 De-oiling elements

#### NOTICE



#### Property damage due to insufficient maintenance!

If the air oil removal devices are strongly polluted, their functioning will be reduced, which can cause machine failures.

- Check de-oiling elements for soiling at regular intervals.
- Replace de-oiling elements after 2,000 operating hours at the latest, or if the filter resistance exceeds 700 mbar (see pressure gauge → accessories, check with short-time atmospheric intake).
- Do not clean the de-oiling elements.
- Always replace the de-oiling elements by new ones.



For monitoring the level of soiling of the de-oiling elements, we recommend using a pressure gauge (ZDM). This enables a check of the filter resistance with temporary atmospheric suction.

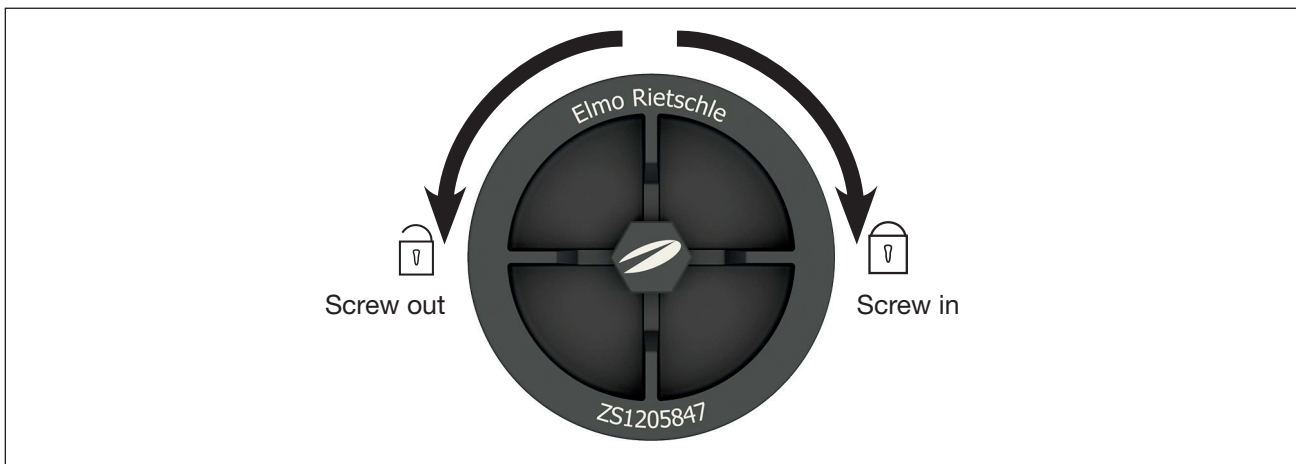

Fig. 8 Air de-oiling element

The air oil removal devices (4x) may be contaminated with particles of dirt when the machine has been running for a long time (power consumption and pump temperature increase).

Reduce the change intervals accordingly depending on how contaminated the discharged medium is.

- Switch the machine off, secure it against accidental switching on and vent to atmospheric pressure. Let the pump cool down.
- Unscrew air oil removal elements (Fig. 7/L) with a ring spanner (width across flats 19 mm) counter-clockwise.
- Push in the new air oil removal elements and screw in clockwise. Tightening torque: max. 15 Nm  
Thee air oil removal elements shall be flush with the oil remover housing.



#### CAUTION

#### Risk of injuries due to improper installation!

DE-oiling elements that have not been installed properly can cause injuries during operation if the pressure in the machine becomes higher than allowed.

- Make sure that the de-oiling elements are screwed in tightly again after being replaced.

## 7.8 Oil cooler and fan

**CAUTION****Danger of injury when dealing with compressed air!**

When the cooler is blown off with compressed air, loose solid particles or powder dust swirling around may cause injury to the eyes. Inhaling can damage lungs.

- Wear protective glasses and dust mask when cleaning the cooler with compressed air.

**NOTICE****Property damage due to insufficient maintenance of the oil cooler!**

Due to soiled cooling ribs of the oil cooler (e.g. From dust) and insufficient maintenance, the cooling capacity of the machine is reduced. This can cause damage of the machine.

- Clean the oil cooler at regular intervals.

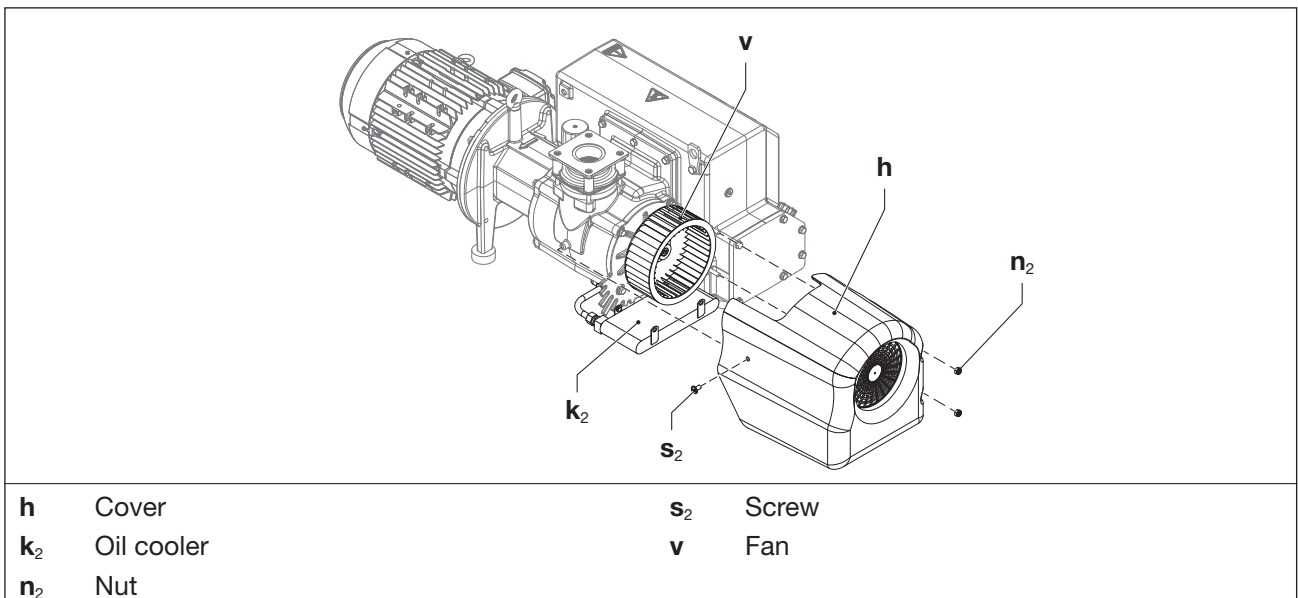

Fig. 9 Oil cooler

- a) Switch the machine off, secure it against accidental switching on and vent to atmospheric pressure. Let the pump cool down.
- b) Release a screw (Fig. 9/s<sub>2</sub>) and two nuts (Fig. 9/n<sub>2</sub>) on the hood.
- c) Remove the hood (Fig. 9/h) from the pump.
- d) Blow-off the oil cooler (Fig. 9/k<sub>2</sub>) and clean from the outside (wipe with a moist cloth).
- e) Clean / blow off the fan (Fig. 9/v) and check it for damages. Operate the fan only if it is in good order and condition.
- f) Clean / blow-off the ventilation slots on the hood (Fig. 9/h).
- g) Push the hood back onto the pump and fix it using the screw (Fig. 9/s<sub>2</sub>) and nuts (Fig. 9/n<sub>2</sub>). Tightening torque: 5 Nm

## 7.9 Motor and coupling

### 7.9.1 Motor



Perform the maintenance of the motor in accordance with the manufacturer's operating and maintenance instructions. For this, contact our service people.

### 7.9.2 Coupling

#### NOTICE

#### Property damage due to defective coupling sleeve!

Defective sleeves can cause breaking of the rotor shaft and blackout failure of the machine.

- Regularly check the coupling sleeve for wear.

#### NOTICE

#### Property damage due to frequent starting and high ambient temperature!

Frequent starting and high ambient temperature reduces the lifetime of the sleeve.

- Regularly check the coupling sleeve for wear.

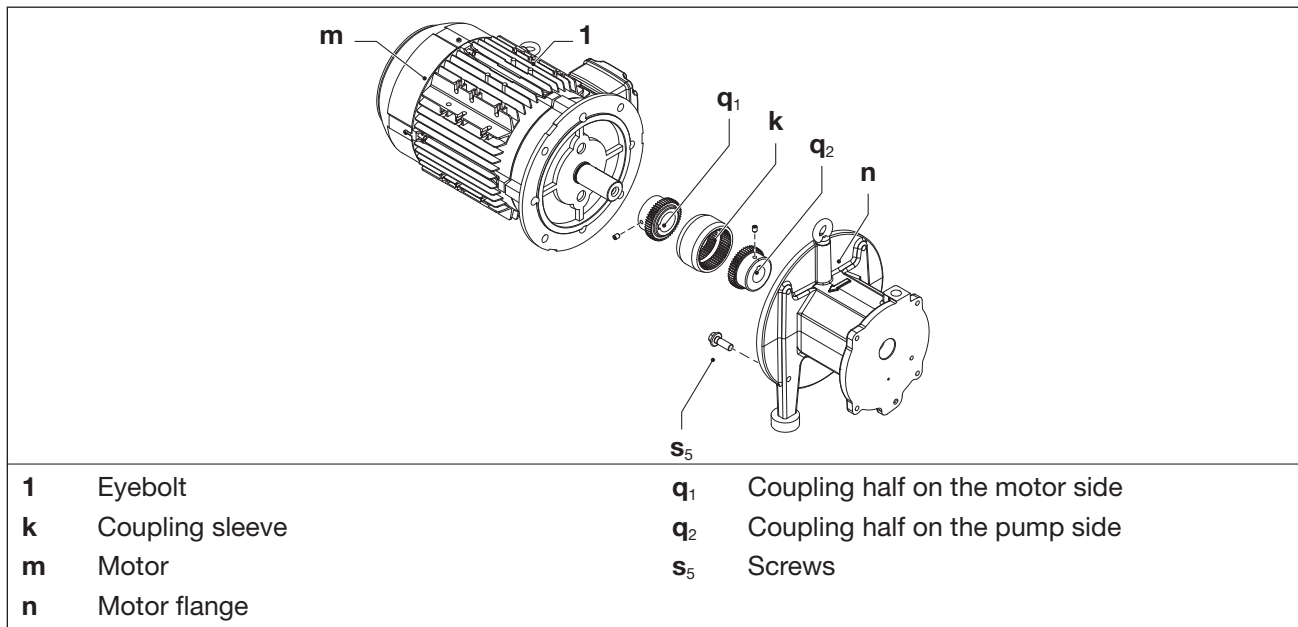

Fig. 10 Coupling

The coupling sleeve (Fig. 10/k) is subject to wear and must be checked regularly (at least 1 x per year).

- a) To check the coupling, switch off the motor (Fig. 10/m) and ensure that it cannot be switched on again.
- b) Tighten the eyebolt on the motor (Fig. 10/1) firmly.
- c) Secure the lifting gear on the ring bolt of the motor.
- d) Undo the screws (Fig. 10/s<sub>5</sub>) on the motor flange (Fig. 10/n).
- e) Remove the motor axially with the coupling half (Fig. 10/q<sub>1</sub>) on the motor side from the motor flange (Fig. 10/n) and suspend with the lifting gear.
- f) Check the sleeve (Fig. 10/k) for damage and replace if necessary.
- g) Push the sleeve and motor with coupling half on the motor side again axially and using bolts (Fig. 10/s<sub>5</sub>) fix to the motor flange (Fig. 10/n). Tightening torque: 90 Nm
- h) Remove the lifting gear from the motor.

## 7.10 Repair / service

For repairs contact the manufacturer, its branch offices or authorised dealers.

Please contact the manufacturer for the address of the authorized service centre (see manufacturer's address at the rear side).



### WARNING

#### Risk of injury due to substances hazardous to health!

Due to contamination with hazardous substances and operating agents during operation, there is a high health risk for the repair personnel.

- For each machine that is sent to an Elmo Rietschle Service centre for inspection, maintenance or repair, a fully completed, signed declaration of harmlessness must be enclosed.  
The declaration of harmlessness is part of the supplier's documentation.
- Before returning, properly clean the machine.

After a repair or re-commissioning, the actions listed in chapter 5 "Installation" and chapter 6 "Commissioning and decommissioning" are to be performed as in the first commissioning.

## 7.11 Spare parts

### NOTICE

#### Property damage due to wrong or defective spare parts!

Wrong or defective spare parts can cause malfunctions or blackout failure of the machine.

- Only use original spare parts or parts approved by the manufacturer.
- The use of other parts may revoke liability or guarantee for any resulting consequences.

Please find an overview of the spare parts in the **List of spare parts E 236**. This can be ordered via the Service or downloaded using the following link:

- <http://www.gd-elmorietschle.com>  
→ Downloads

Wearing parts and sealings are separately listed. For ordering spare parts, please contact the Elmo Rietschle Service (address on the back of the page).

For a simple and fast maintenance we are offering several service kits for our vacuum pumps. They include all wearing parts and sealings that are required for the respective maintenance works.

These service kits and oil types can directly be ordered from our Elmo Rietschle Service with quotation of the material numbers.

Service kits	Material number	Description
<b>Standard maintenance kit</b> 500 - 2,000 h	1029350102	Includes*: 4x air oil removal elements, 1x sealing oil eye, 1x sealing oil filler
<b>Extended service kit</b> ab 6,000 h	1029350104	Includes*: 4x air oil removal elements, 1x sealing oil filler, 1x coupling sleeve, 1x O-ring, 1x filter disc, 1x locking ring, 1x non-return valve, 1x filter cartridge, 1x oil inspection glass, 1x metal float

Tab. 2 Service kits

\* Please find the exact positions in the service drawing E236.

## Maintenance and repair

Service kits	Material number	Description
<b>General overhaul</b>		
Set of wearing parts		
VCS	1029350103	Includes all wearing parts.
VCX	1029360103	
Set of sealings	1029350101	Includes all sealings.

Tab. 2 Service-kits (continued)

Oil	Trading units	Material number	Description
<b>Multi-Lube 100</b> 500 - 2,000 h	Canister, 20 l	7204866000	Standard oil based on mineral oil
	Canister, 5 l	7202096000	
	Canister, 1 l	7202126000	
<b>Super-Lube 100</b> 500 - 3,000 h	Canister, 20 l	7204876000	Synthetic oil, for longer oil change intervals at high thermal load of oil, e.g. ambient or intake temperatures above 30 °C, insufficient cooling, 60 Hz-operation.
	Canister, 5 l	7201466000	
	Canister, 1 l	7201586000	
<b>ECO-Lube 100</b> 500 - 2,000 h	Canister, 5 l	7201486000	Synthetic oil for the food and pharmaceutical industry with H1 certificate

Tab. 3 Oils



## 8 Errors



### Danger to life!

If malfunctions are disregarded and/or removed only insufficiently, serious to lethal injuries can occur.

- Never put the pump in operation again after it has been switched off automatically without unequivocally finding out the reason for this shut-off and remedying it.

### 8.1 Table of malfunctions

Malfunction	Cause	Elimination	Note	
Machine is switched off by the motor protection switch	Mains voltage/ Frequency does not correspond with the motor data	Check by qualified electrician	Chapter 5.5	
	Connection to motor terminal board is not correct			
	Motor protection switch is not set correctly			
	Motor protection switch is triggered too quickly	Use a motor protection switch with an overload-dependent delayed switch off that takes into consideration the short term excess current at start up (version with short circuit and overload trigger as per IEC 60947-4-1)		
	Vacuum pump or its oil is too cold	Note the ambient temperature and the inlet temperature		Chapter 2.4
	The lubricating oil is too viscous	The oil viscosity must comply with ISO VG 100 as per DIN ISO 3448		Chapter 7.6
	The air oil removers are dirty.	Change the air de-oiling elements		Chapter 7.7
	The back pressure in the exhaust line is too high	Check the hose and/or the pipe		Chapter 5.3
	Permanent operation >100 mbar (abs.).	Use next largest motor output		Chapter 4.4
Pumping capacity is insufficient	The inlet pipe is too long or too narrow	Check the hose and/or the pipe	Chapter 5.3	
	Leak on the inlet side of the vacuum pump or in the system	Check the pipework and screw connections for leaks and check for tight fit	Chapter 7.2	
	The intake filter is dirty	Clean or replace the intake filter	Chapter 7.5	

Tab. 4 Table of malfunctions

## Errors

Malfunction	Cause	Elimination	Note
Final pressure (max. vacuum) is not reached	Leak on the inlet side of the vacuum pump or in the system	Check the pipework and screw connections for leaks and check for tight fit	Chapter 7.2
	Incorrect oil viscosity	The oil viscosity must comply with ISO VG 100 as per DIN ISO 3448	Chapter 7.6
Machine gets too hot	Ambient or inlet temperatures too high	Ensure proper use	Chapter 2.4
	Cooling air supply is obstructed	Check ambient conditions	Chapter 5.1
		Clean ventilation slots	Chapter 7.8
	Soiled oil cooler	Clean the oil cooler and fan, renew the fan if necessary	Chapter 7.8
	The lubricating oil is too viscous	The oil viscosity must comply with ISO VG 100 as per DIN ISO 3448	Chapter 7.6
	The air oil removers are dirty.	Change the air de-oiling elements	Chapter 7.7
The back pressure in the exhaust line is too high	Check the hose and/or the pipe	Chapter 5.3	
Exhaust air contains visible oil mist	The air oil remover devices are not inserted correctly or the O rings are missing.	Check that it is correctly seated	Chapter 7.7
	Unsuitable oil is being used	Use suitable types	Chapter 7.6
	The air oil removers are dirty	Change the air de-oiling elements	Chapter 7.7
	Ambient or inlet temperatures too high	Ensure proper use	Chapter 2.4
	Cooling air supply is obstructed	Check ambient conditions	Chapter 5.1
Clean ventilation slots		Chapter 7.2	
The machine makes a strange noise (The blades making a hammering noise when starting from cold is normal if it disappears within two minutes as the operating temperature increases)	The pump housing is worn (chatter marks)	Repair by manufacturer or authorised workshop	Elmo Rietschle Service
	The vacuum adjustment valve (if available) is vibrating	Replace the valve	Chapter 7.11
	Blades are damaged	Repair by manufacturer or authorised workshop	Elmo Rietschle Service
	Vacuum pump or its oil is too cold	Note the ambient temperature and the inlet temperature	Chapter 2.4
	The lubricating oil is too viscous	The oil viscosity must comply with ISO VG 100 as per DIN ISO 3448	Chapter 7.6

Tab. 4 Table of malfunctions (continued)

Malfunction	Cause	Elimination	Note
Water in lubricating oil	Pump sucks in water	Install water interceptor upstream of the pump	—
	The pump sucks in more water vapour than is suitable for its water vapour compatibility	Contact the manufacturer for increased gas ballast	—
	Pump only works for a short time and therefore does not reach its normal operating temperature	Let the pump continue to run with a closed suction side after extracting the water vapour until the water has evaporated from the oil	—

Tab. 4 Table of malfunctions (continued)



Please contact Elmo Rietschle Service for other malfunctions or those that cannot be eliminated.

### 9 Disassembly and disposal

#### 9.1 Disassembly



#### WARNING

#### Risk of injury due to substances hazardous to health!

Due to contamination with hazardous substances and operating agents during operation, there is a high health risk for the personnel.

- Before disassembly, properly clean the machine.
- Wear suitable protective clothing.

- a) Put the machine out of service according to chapter 6.3.
- b) Disassemble the machine.  
Dismantle large components and assemblies.

#### 9.2 Disposal

#### NOTICE



#### Damage to the environment!

Environmental damage may be caused by the incorrect disposal of operating material and materials.

- All operating materials as well as all fluids such as cooling water and cooling oil required during operation and maintenance must be collected and disposed of in an environmentally friendly manner.
- Separate components according to the materials and if possible, recycle.

- a) Collect oils and grease separately and dispose of in accordance with the local regulations in force.
- b) Do not mix solvents, cold cleaning agent and paint residues.
- c) Remove components and dispose of them in accordance with the local regulations in force.
- d) Dispose of the machine in accordance with the national and local regulations in force.
- e) Parts subject to wear and tear (marked as such in the spare parts list) are special waste and must be disposed of in accordance with the national and local waste laws.

## 10 Technical Data

			VCS 200	VCS 300	VCX 200	VCX 300
Sound pressure level (max.) EN ISO 3744 Tolerance ± 3 dB(A)	dB(A)	50 Hz	71	77	74	78
		60 Hz	76	80	78	82
Sound power level	dB(A)	50 Hz	–	–	83	85
		60 Hz	–	–	86	89
Weight *	kg	50 Hz	168	168	168	168
Length *	mm	50 Hz	973	973	973	973
Width	mm		520	520	520	520
Height (without terminal box)	mm		388	388	388	388
Vacuum connection			G2	G2	G2	G2
Exhaust-air outlet			G2	G2	G2	G2
Oil filled volume	l		6	6.5	6	6.5

Tab. 5 Technical Data

\* Length and weight may differ from the information listed here depending on the motor manufacturer.

Please find more technical details in the data sheets **D 236** → V-VCS / X 200 | 300

- Download the PDF file: <http://www.gd-elmorietschle.com>  
→ Downloads



Subject to technical changes!



**Elmo  
Rietschle**

[www.gd-elmorietschle.com](http://www.gd-elmorietschle.com)  
[er.de@irco.com](mailto:er.de@irco.com)

---

**Gardner Denver**  
**Schopfheim GmbH**  
Johann-Sutter-Straße 6+8  
79650 Schopfheim · Germany  
Phone +49 7622 392-0  
Fax +49 7622 392-300

**Gardner**  

---

**Denver**

Elmo Rietschle is a brand of  
Gardner Denver's Industrial Products  
Division and part of Blower Operations.